



WHR 10MW Generation Project

DRIVING INNOVATION AND SUSTAINABILITY

“Utilising technologies developed in the 21st century, to provide innovative, environmentally friendly and financially viable green solutions”

December 2025

Confidential



Green Power - The Opportunity

- Green Power Tech is planning on establishing a 10MW WHR (Waste Heat Recovery) base load generation plant on the island of Mauritius.
- The 1st WHR project in Mauritius requires \$35.65 Million in funding, in return for a 40% equity shareholding in the project and capex repayments at a 10% interest rate over 10 years
- The generation boiler will be heated from the activated carbon plant waste energy, that will be constructed concurrently with the turbine generation plant. The power generated from a low pressure, temperature, revolution turbine will be sold to the CEB (Central Energy Board) in Mauritius
- The WHR project fits into the Mauritius' regulatory framework for energy efficiency and GHG reductions under Nationally Determined Contributions (NDCs) and the Climate Change Act that supports generation projects of this nature.
- It is a high-return investment project which emphasizes energy efficiency and GHG reductions.
- High ROI, IRR, and net profits over a 20-year life, after an 8-year tax holiday and subsidized tax rate of 15%.



The Opportunity Contd.

- The water and energy use in both the AC and WHR plant is low, the WHR heat source is free, 90% of all water used in the system will be recirculated. The AC plant and generation plant do not produce any waste.
- With the WHR generation plant using the AC plant heat source, the project can earn substantial carbon credit returns, as there is no fossil fuel required to heat and run the WHR generation plant.
- Carbon credits that will be earned from the process can be sold to various international companies like Amazon, Google, Microsoft etc. and increase revenues over the life of the project by nearly 40%
- Tax rates on company profits, government rebates on power projects and foreign currency regulations are extremely favourable for doing business in Mauritius
- The capital investment can be recouped via subsidies available from the Mauritius Government for industrial and power projects (Refund up to 80% of project cost)
- Green Power has the option to either rent or purchase a warehouse in Mauritius to construct the 1st WHR plant.



Use of Funds

- Capex requirement US\$35 million (+/-10%) to purchase a warehouse, construct and commission an activated charcoal plant, a full waste heat recovery boiler-turbine-generator setup.
- This is based on capital costs of \$2,500/kW - \$3,500/kW for small waste heat steam plants, adjusted for 2026 market data.
- The WHR project and equipment setup includes following:
 - \$1.65M for AC plant, auxiliaries, installation, controls, warehouse purchase setup
 - \$23M for boiler, auxiliaries, installation, controls (Size 60 t/h at 20 bar pressure)
 - \$7M for 1500 RPM turbine and generator, condenser, auxiliaries, installation, controls
 - \$3.35M for chimney integration, breaker yard and grid connection
- Construction is normally between 18 months and 36 months (Including permitting, procurement, site prep, erection, commissioning). A shorter period of 12 months to 18 months for modular designs in favorable locations like Mauritius can be achieved.
- A comprehensive feasibility study has been completed for the business operations and available for review



Revenue and Profit

- Financial projections are taken over a 20-year operational life with the following key financial indicators used for calculating returns:
 - ✓ **Total Capex Requirements:** US\$ 30,000,000 for boiler, turbine, generator, warehouse and \$3,350,000 for chimney integration and breaker yard to grid connection. (\$1,650,00 AC Plant)
 - ✓ **ROI:** 34.5%
 - ✓ **NPV at 8% Discount (of EBITDA):** US\$ US\$ 30,716,2478 (over 20 years, present value of annual EBITDA discounted at 8%).
 - ✓ **Repayment of Capex at 10% Interest:** Annual payment of US\$ 3,400,385 year (1) for a 10-year term (amortized loan covering principal and interest - payback 5 years based on average EBITDA).
 - ✓ **Total EBITDA:** US\$ 212,495,275
 - ✓ **Net Profit After 5% Tax:** Annual net profit US\$ 3,492,650 (1) and US\$ 156,499,245 over 20 years.



WHR Process

1. The process electricity generation is indicated the figures next
2. The boiler design and all equipment required for the generation plant is provided by the OEM manufacturer

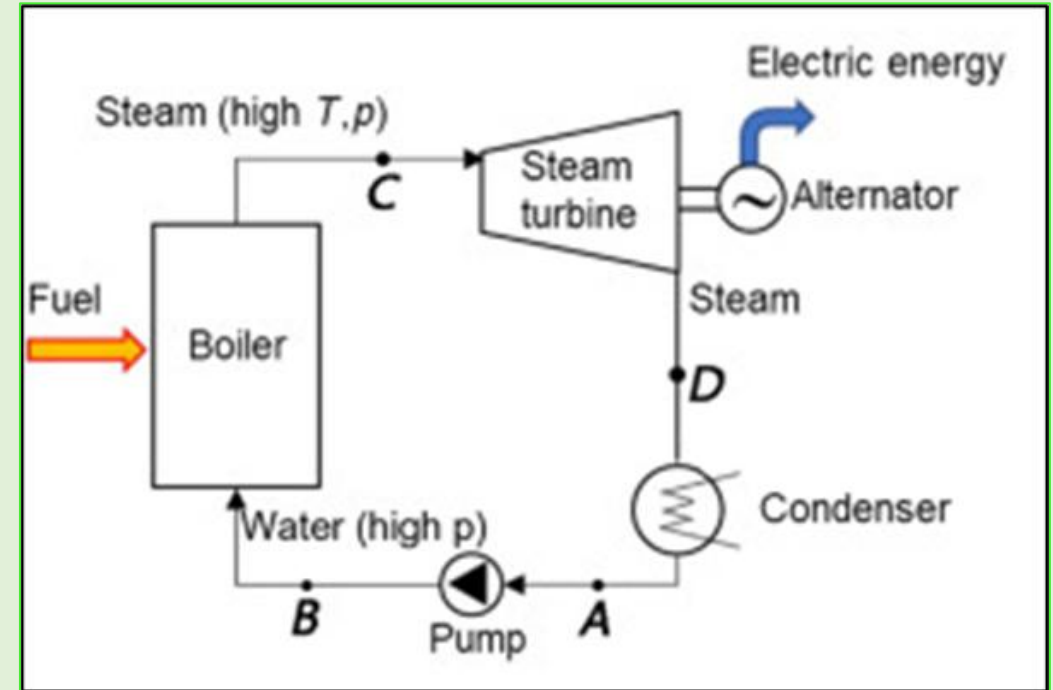
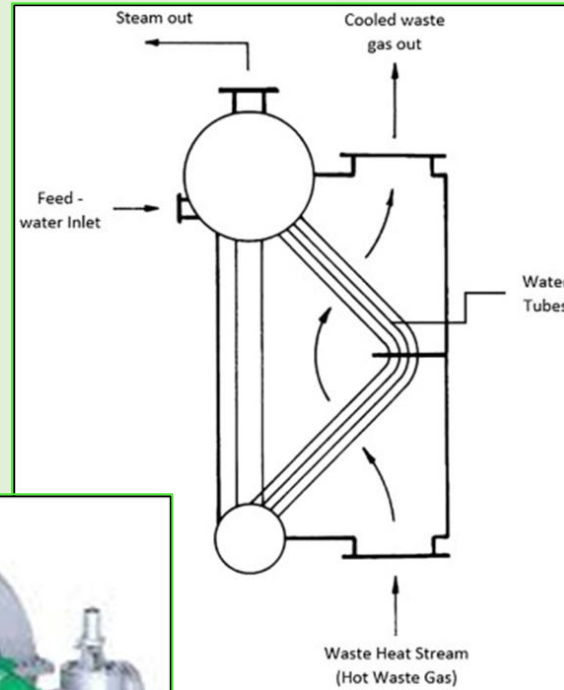

WHR Plant Location

- Mauritius and Reunion are situated in the Indian Ocean 2400 Kms from the East coast of Africa and 900Km's from Madagascar

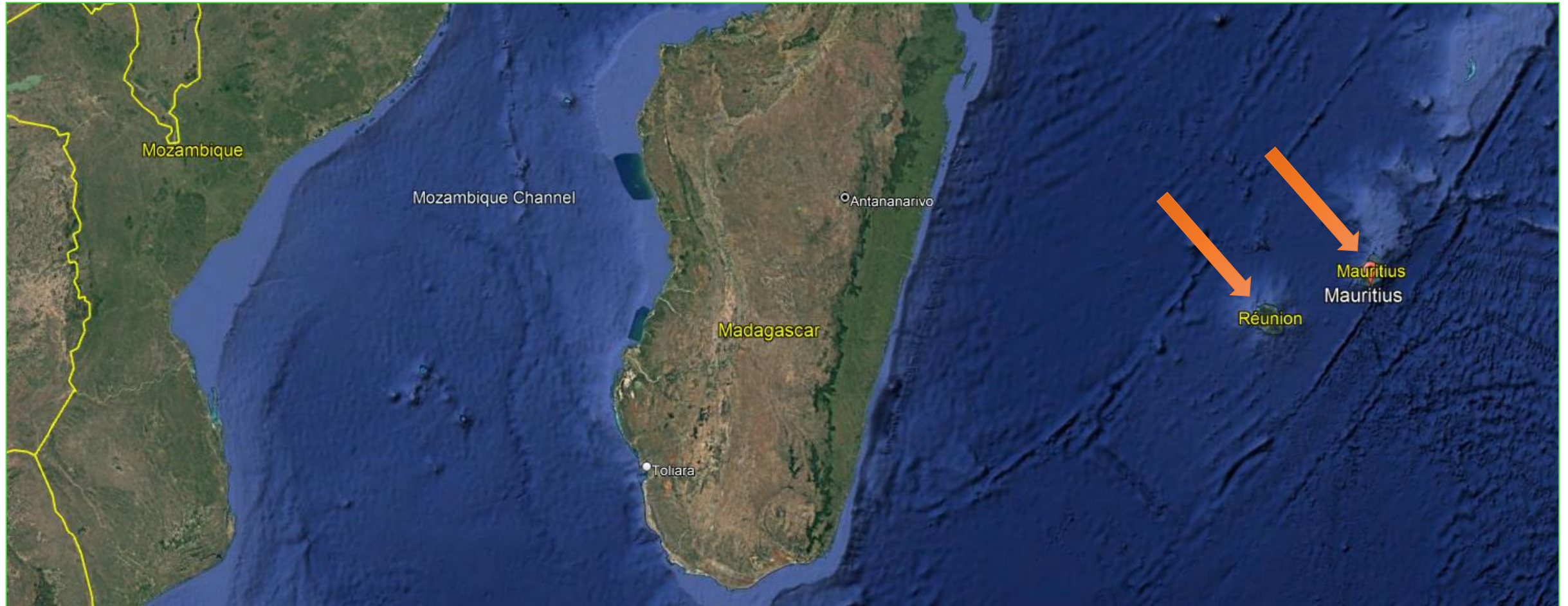

WHR Plant Location



- Based on the project's integration with the AC plant (using agricultural waste like bagasse or coconut shells for feedstock) and the need for proximity to waste sources, grid connections, and industrial infrastructure, the area of L'Escalier in the Savanne District (Southern Mauritius) is recommended as an ideal location.
- The WHR plant can also be constructed in the AC project warehouse possibly selected on the outskirts of Port Louis in the Riche Terre Industrial zone
- The warehouse in the industrial zone is within 5 km of the port and has easy access to the main M2 Highway that dissects the island.
- The access to the M2 allows for the collection of biomass from across the island and North and South

Management Team



Colin Lotter CEO – Is a dynamic force in engineering and sustainable development, with qualifications in both electrical and mechanical engineering.

He has 30 years of experience in project management, coal mine establishment, coal washing plant construction and industry applications of carbon-based products. Coupled with a complete understanding of charcoal manufacturing from both coal and biomass, he will provide hands on management of the activated charcoal operations



Bianka Louw CFO – Has more than 15 years of experience in business management and administration, with an excellent understanding of establishing practical and digital control systems that allow for efficient business operations

Her experience in water sanitation, alternative natural medicines, and environmental sustainability suit the activated charcoal business model and will allow for smooth implementation of the project.





For more information email or contact:

Colin Lotter - (+27) 76 389 3880
colin@cjlc.co.za or colin@greencointech.com

Bianka Louw – (+230) 59 35 5252
bianka@cjlc.co.za or bianka@greencointech.com

